

SLF/SUF-350C

roll to roll handling system

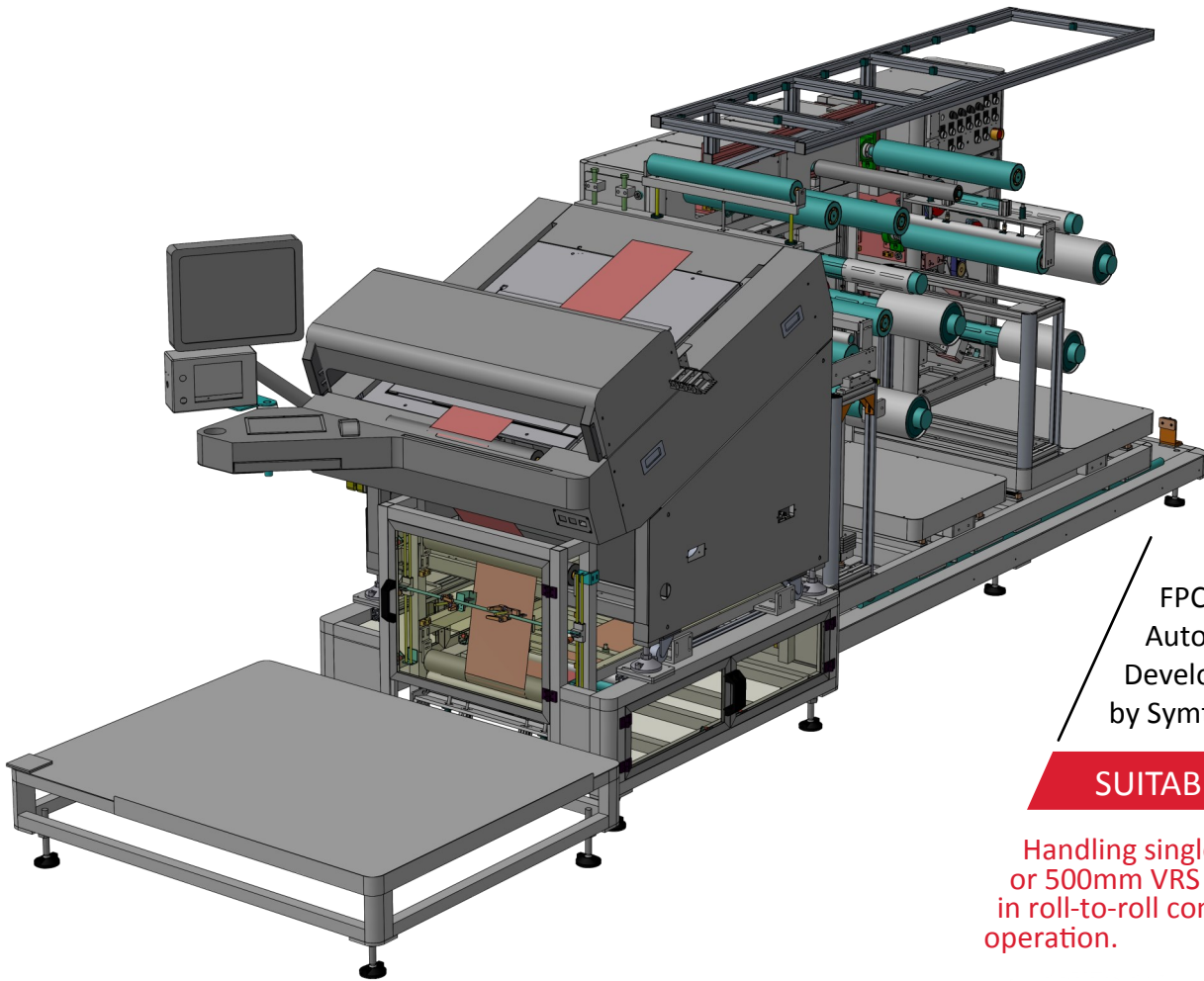

FPC
Automation
Developed
by Symtek

SUITABLE FOR

Handling single 250mm
or 500mm VRS material
in roll-to-roll continuous
operation.

DESCRIPTION

- 1 The board elements are reeled into the machine and pulled sequentially through the rollers.
- 2 After the board is processed it is wound onto the receiving rollers of the unloading system.
- 3 The system can automatically detach the protection foil before processing and laminate with a new one afterwards.
- 4 The machine is be equipped with a buffer system to connect foils for continous production.
- 5 The connection of foils needs to be done manually on an integrated connection table.

SAA
Symtek Automation Asia

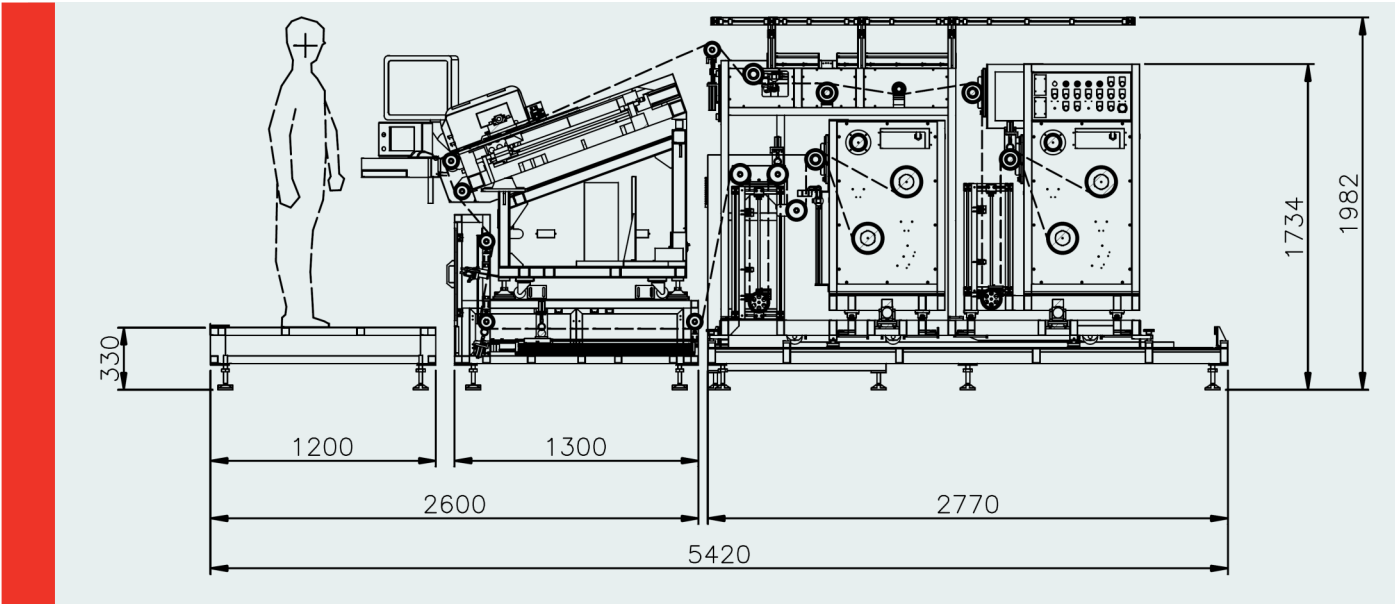

TYPE		
DIMENSIONS (LxWXH)		
WORKING HEIGHT		
MAX. PANEL SIZE		
MIN.PANEL SIZE		
PANEL THICKNESS		
STACKING THICKNESS		
THROUGHPUT		
POWER		
AIR		